

SunBee

Transporter



INSTRUCTION MANUAL

This manual contains important safety, assembly, operation and maintenance information.

Please read and fully understand this manual before operation.

Save this manual for future reference.

Owner's Manual Index

Introduction

- The Owner's Responsibility
- Trailer Compatibility.
- Reflectors
- Trailer Warnings
- Pre-Ride Safety Check

Components

- Part Assembly View.
- Parts Assembly List

Assembly

- Introduction to Assembly
- Assembling the Frame
- Setting up the Hitch Arm
- Installing the Wheels.
- Installing the Push Bar and front wheel
- Attaching the Trailer to Bike
- Attaching Safety Strap to Bike
- Fixed the front wheel as trailer
- Installing Flag

The Owner's Responsibility



WARNING: The trailer is designed and constructed to provide a portable, comfortable and sturdy addition to your outdoor ventures. Please read these instructions and all warnings carefully before using and keep the instructions for future reference.

If the Trailer was purchased unassembled, it is the owner's responsibility to follow all assembly and adjustment instructions exactly as written in this manual, and any "special instruction" supplied to ensure complete and proper assembly. Make sure all fasteners and components are securely tightened during installation.

NOTE:

- Periodically check that all fasteners and components are securely tightened.
- Check the working conditions of both bike and trailer before each use. If you discover broken components, misalignment or missing parts, correct the problem prior to use.

If the Trailer was purchased assembled, it is the owner's responsibility before using the Trailer for the first time, to make sure the Trailer has been assembled and adjusted exactly as written in this manual, and any "Special Instructions" supplied and to make sure all fasteners and components are securely tightened.

Thank you for your purchase. If you have problems, do not return to store. Call customer service. Please refer to model/date code label on product or cover of manual.

Warning and Safety Information

Reflectors



WARNING: For your safety, do not use the Trailer if the reflectors are incorrectly installed, damaged, or missing. Make sure the reflectors are vertical and pointing straight back. Do not allow the visibility of the reflectors to be blocked by clothing or other articles. Dirty reflectors do not work well. Clean the reflectors, as necessary, with soap and a damp cloth.

Trailer warnings



WARNING: Failure to comply with the manufacturer's instructions can lead to serious injury or death of the passenger/ rider.

- Adult assembly required.
- This trailer is only for cargo use, not for use as a child carrier.
- **Only use bicycles with 26" or 28" wheels capable of pulling a 40 kg trailer. Contact your manual or bicycle retailer for more information**
- **Caution on driving behavior of cycle/cycle trailer set, especially when driving downhill or around corners.**
- Never exceed a safe speed. Recommended maximum speed is 8 MPH (13KMH) and slowing to no more than 3 MPH(5KMH) when turning.
- Not for cargo (such as but not limited to bricks, debris, logs, etc.).
- **As cargo trailer: Maximum weight is 88lb (40KG). Maximum load weight is 66lb (30KG).**
- Riders must wear an approved bicycle helmet when riding in this product.
- The trailer is not suitable for running or skating. Do not use trailer in snow or icy conditions.
- Do not install a car seat or any other seating device not approved by the manufacturer inside the trailer.
- Do not use on rocky or uneven road surfaces.
- Do not park near inclines or uneven roads that may cause the trailer to tip.
- Make no modification to the trailer.
- Before each ride, ensure the attached trailer and trailer components do not interfere with braking, pedaling, or steering of the bicycle.
- Never use a trailer at night or times of limited visibility.
- Obey all local laws and regulations for bicycles and trailers.
- Check all fasteners before each ride.
- Ensure lock pins are fully inserted/engaged before each ride.
- Always use the safety flag when pulling this trailer.
- The bicycle to which the trailer is attached should undergo a safety check by a qualified bicycle mechanic before attaching the trailer to it.

- Check tires before rider. Inflate tires to recommended pressure shown on tire sidewall.
- Ensure brakes on your bicycle work properly before each ride. Braking distance is increased when pulling a trailer.
- Do not use cleaning solvents. Clean only with soap and water.

Draw bar Load between 30N and 80N !

Checking the draw bar load:

Pull the draw bar up to the front of the bike.

Pull it up straight ahead with the tension meter.

The tension range is between 30-80N.

- Note to draw the attention of the user to possible nation legal requirement when the cycle is to be used on public roads (e.g.lighting and reflector)
- Cycle trailers pulled by an EPAC can be restricted by law.
- The person riding the towing bicycle should be at least 16 years of age and in good physical condition.
- On the negative influence of the trailer on the braking distance of the cycle when the trailer is attached.

Pre-Ride Safety check

Before each ride:

1. Ensure Bike and Trailer are in top working condition.
2. Check TIRE AIR PRESSURE of both Bike and Trailer.
3. Check to ensure Hitch Connector and Safety Strap are secured.
4. Secure all cargo and fasten top cover.
5. HELMETS ON! Ensure rider is on and secure.

Components

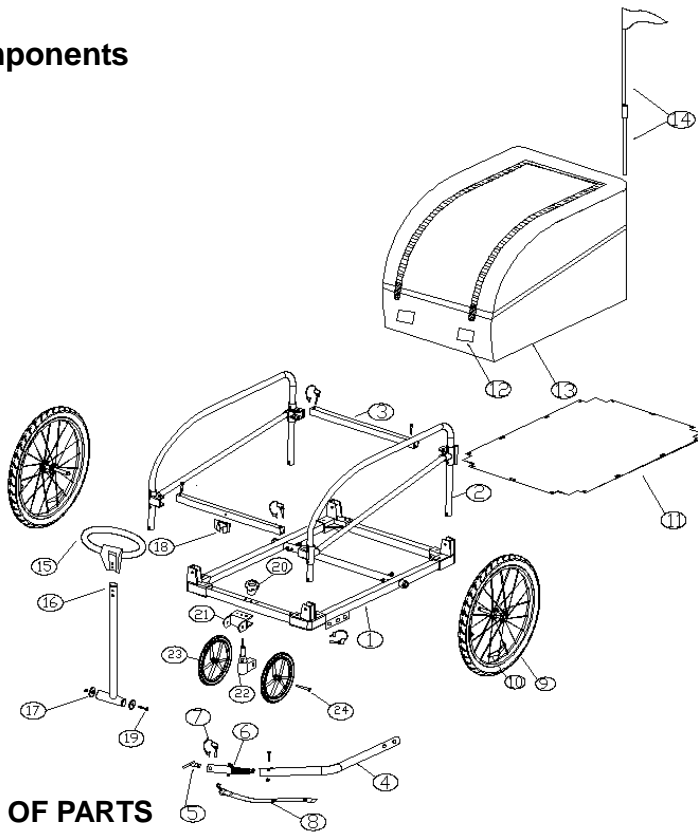

BILL OF PARTS

No	NAME	Q'TY	No	NAME	Q'TY
1	Base Frame	1	13	Bag	1
2	Side Panel	2	14	Flag	1
3	Front/ Rear Panel	2	15	Push bar	1
4	Hitch Arm	1	16	Push tube	1
5	Hitch Clamp	1	17	Screw	1
6	Spring	1	18	Hook	1
7	Safety pin	1	19	Knob	1
8	Safety Strap	1	20	Knob	1
9	Rear wheel	2	21	Connector board	1
10	Reflector	4	22	Base of front wheel	1
11	Board	1	23	Front wheel	2
12	Front/Rear reflector	4	24	Axle of front wheel	1

Introduction to Assembly

This Owner's Manual is made for several different Trailers:

- Some illustrations may vary slightly from the actual product.
- Follow instruction completely.
- If the trailer has any parts that are not described in this manual, look for separate "Special Instructions" that are supplied with the Trailer.
- Models may have different accessory items such as bags, baskets, reflectors, cup holder, rack, etc.
- All features, components and accessories are not included no all models.
- Use the index page to locate specific sections of this manual.
- Please read through this entire manual before beginning assembly or maintenance.
- If you are not confident with assembling this unit, refer to local bike shop.



WARNING: Keep small parts away from children during assembly.

NOTE: All of the directions (right, left, front, rear, etc.) in this manual are as seen by the rider.

Do not dispose of the carton and packaging until you complete the assembly of the Trailer. This can prevent accidentally discarding parts of the Trailer.

Assembling the Frame

Remove trailer and all components from carton and sort all contents.

Steps:

1. Place the cargo basket frame on a flat surface.
2. Unfold Side Frames so they are upright.
3. Then unfold other two-directions Frame, push side frames apart and insert end of bar into clamp bracket.
4. Insert Safety Pin and snap clip ring over end of Safety pin as show.



Setting up the Hitch Arm

Steps:

1. Turn the unit on its side.
2. Remove the Safety Pin from rear hole as shown.
3. Rotate Hitch Arm so that it points forward.
4. Insert Safety Pin in FORWARD hole and snap clip ring over end of Safety Pin as shown.

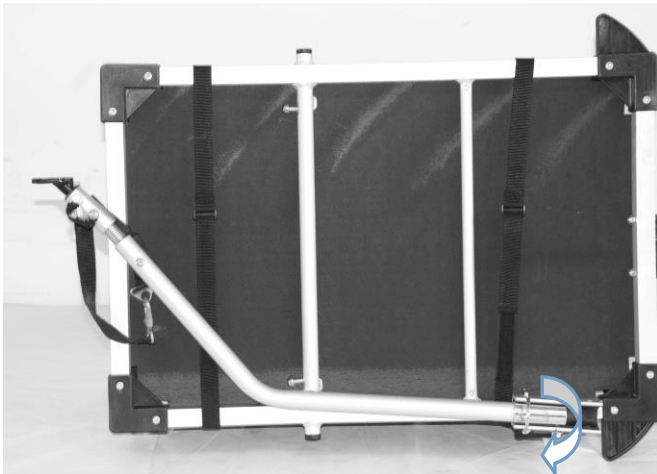

Safety Pin

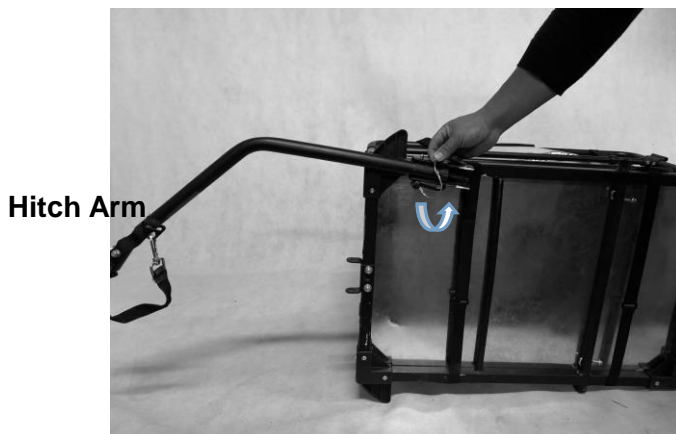

Hitch Arm



WARNING: Do not use the trailer without proper installation of the safety pin.

Installing the Wheels

Steps:

1. Turn the unit on its back.
2. Slide each Wheel Shaft (A) into the Trailer Axle (B).
3. Press the Lock Button (C) until the Wheel locks into position and cannot be pulled out.
4. Repeat for opposite side.

NOTE: To remove the Wheel, push in the Lock Button and pull the Wheel out of the Axle.

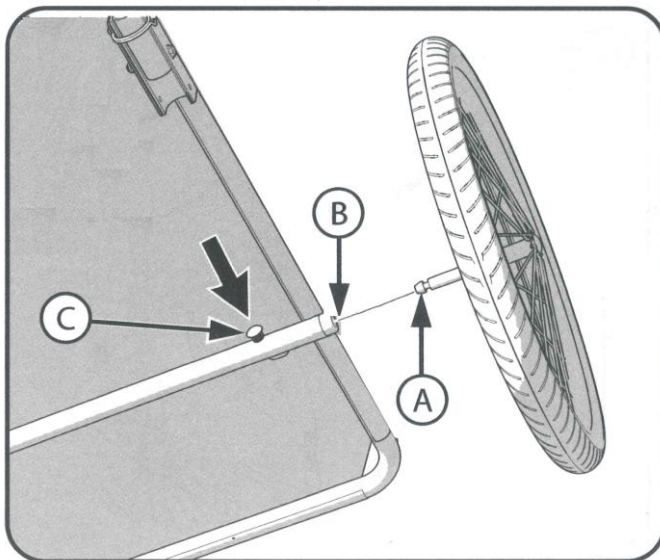

WARNING:

- For easy towing and safe handling, check tires often for proper inflation and wear. Check tire pressure regularly and inflate tires to within the range shown on the tire sidewall.
- Failure to properly install wheels could allow them to come off during use. This could lead to serious injury.

Installing the Push Bar and front wheel

Steps: see the picture as blow



1. insert front wheel to hole



2. spin the knob

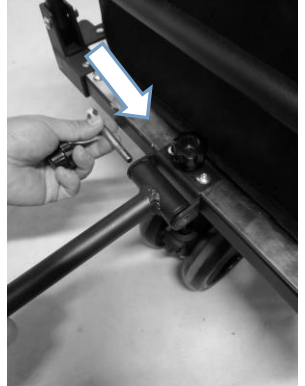

3. insert the screw to hole



4. spin the knob



5. parking



6. Pushing



7. Fixed pull handle

Attaching the Trailer to Bike

Steps:

(Hitch Connector (9) may be pre-install from the factory)

1. Insert the Hitch Connector (9) into the Hitch Arm (5).
2. Insert Safety Pin (7) and snap Clip Ring (A) over end of Safety Pin as shown.

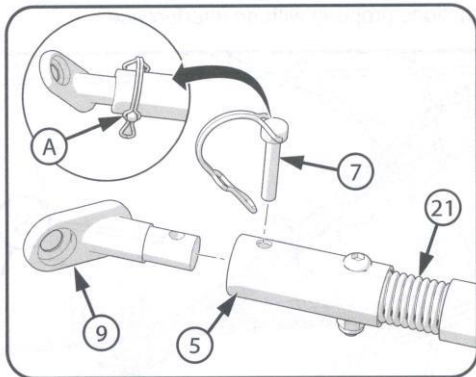

3. Remove the left rear Axle Nut (A) from the bike.
4. Fasten the Hitch Connector (9) onto the rear axle using the existing Axle Nut as shown.
5. Ensure wheel is properly aligned and chain properly tightened as described in bicycle owner's manual.
6. Install and tighten Axle Nut as described in bicycle owner's manual.

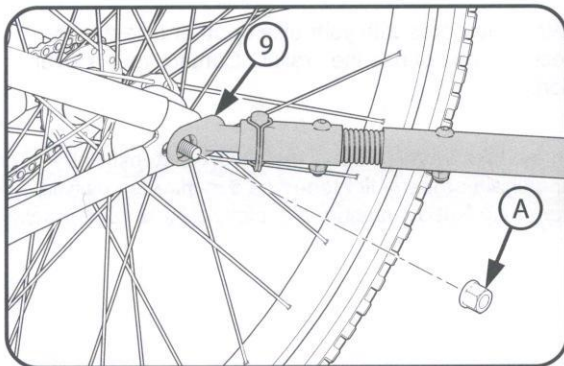

WARNING: Ensure there is fully thread engagement and threads are visible past the end of the nut.

If there are not threads visible past the end of the nut, contact a local bicycle shop for proper installation.



WARNING: If the Hitch interferes with your bike or other bike attachments, or if it

does tighten securely, do not use the Trailer. Contact a local bicycle shop for help with proper installation.

Attaching Safety Strap to Bike

Steps:

1. Route Safety Strap (20) around Bike's Frame (A) as shown.
2. Securely fasten Strap Clamp (B) to Bracket (C) as shown.
3. Ensure wheel functions properly with no interference.

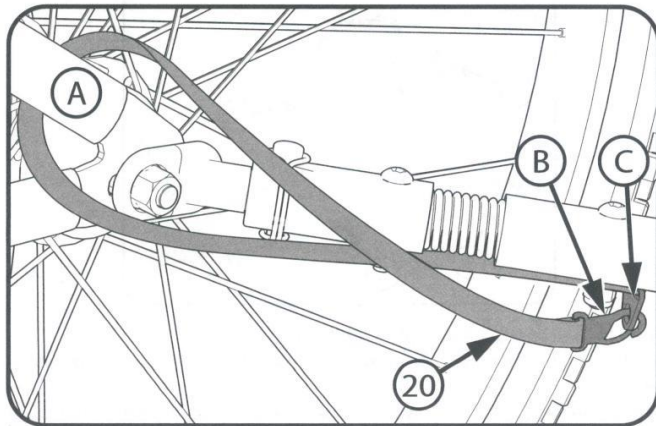

WARNING: If the Safety Strap interferes with your bike or other bike attachments, or if it does not tighten securely, do not use the Trailer. Contact your local bicycle shop for proper installation.

NOTE: To remove the Trailer from the bike, reverse these installations steps. Ensure wheel is properly aligned and chain properly tightened as described in bicycle owner's manual. Install and tighten Axle Nut as described in bicycle owner's manual.

Fixed the front wheel as trailer



Installing Flag

The Flag slides into the Slot in the side of the left Frame.

Steps:

1. Connect both sections of the Flag as shown.
2. Locate the Slot on the rear corner of the frame and slide flag shaft all the way in so that it is secure.



WARNING: Do not use Trailer without Flag installed.

WARNING:
ALWAYS WARE YOUR HELMET WHEN RIDING WITH THIS
PRODUCT!

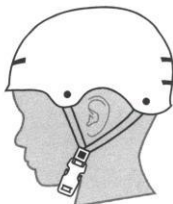

CORRECT



INCORRECT