



Bike Trailer

User manual

Important: Read the following instructions carefully before use and keep them for future reference.

Important: Lire les instructions suivantes attentivement avec utilisation et les conserver pour les besoins ultérieurs de référence.

INDEX

Warnings (EN)	3
Maintenance (EN)	5
Parts list	6
Assembling the base frame	7
Attach the rear wheels	8
Attach the front wheels	9
Attach the jogger wheel	10
Extend & secure the tow bar	11
Insert the safety flag	12
Assembling the reflectors	13
Using the parking brake	14
Using the safety harness	15
Back rest adjustment	17
Check before use	19

WARNINGS

- **Do read instructions before driving. Failure to comply with the instructions and warnings in this manual could result in serious injury or death.**
- The maximum total load: 44kgs
- The maximum load: 22kgs
- Max recommended trailer speed is 15km/h. Always maintain a safe speed.
- Do not use the trailer on rocky roads or other dangerous roads.
- Never leave children in or near the trailer unattended.
- Never have more than two children in the trailer at one time.
- Never use with children who cannot support their own head.
- Never use the trailer with children who cannot sit unaided.
- Bicycle riders using the trailer must be 18 years old or older and must be in good physical condition.
- Riders and children must wear approved safety helmets.
- The weight and the age of the child for which the vehicle is suitable up to 22 kg or 4 years whichever comes first.
- Assemble trailer strictly according to this instruction manual.
- Never park the trailer near a trench or dangerous road.
- Check tire air pressure before every trip.
- If necessary inflate the tires to within the range shown on the tire sidewall.
- Always use a foot or hand pump to inflate the tires.
- Overinflation of tires may result in failure and risk of serious injury.
- Do not exceed maximum pressure as shown on tires.
- Check that the bicycle is in proper technical condition.
- Always check the proper connection of the coupling.
- Always have the canopy in place.
- Take proper precautions while riding in traffic, especially when turning.
- Always check that all parts of the trailer are connected properly and tightly.
- Do not use trailer with motorized vehicles. Increased speed of motorized bicycles can damage the trailer and cause injury.
- Avoid serious injury from falling or sliding out. Always use the safety harness.
- Take extra precautions when using in the rain. Ride slowly and allow a greater margin of safety when starting, stopping, and turning.
- Do not ride on surfaces where sand, gravel, ice, oil, or slippery substances are present.
- Never tow the trailer over curbs, stairs or escalators. If you must travel through stairs, have children get out of the trailer, disconnect the trailer from the bike and take it over the stairs independently.
- Never use bike trailer without provided safety flag and reflectors.
- Do not make any modifications to the trailer which may increase the risk of failure.

- Check the trailer for damage. Do not use if damaged.
- Be sure the fasteners are tight. Tighten if necessary.
- Be sure the brakes work properly. Braking distance is increased when pulling a trailer.
- The trailer requires a wide turning radius. Do not turn sharply. Sharp changes in direction may cause a tip over.
- The assembly can only be carried out by an adult.
- Use caution when turning on loose or uneven surfaces and when going downhill.
- Allow extra clearance for the trailer when near curbs, parked cars, and other obstacles.
- Do not ride over curbs, bumps or holes.
- Do not use the trailer in hazardous weather.
- Do not pull or push the trailer with a vehicle.
- This product is not suitable for running or skating.
- Red reflectors must be visible on the rear of the trailer.
- Never ride a bicycle at night without adequate lighting. Obey all local legal requirements for lighting.
- Any load attached to the handle and/or on the back of the backrestand/or on the sides of the vehicle will affect the stability of the vehicle.
- Accessories which are not approved by the manufacturer shall not be used.

MAINTENANCE

- Maintain and clean the trailer regularly to keep it in good condition for a long time.
- Check your trailer and accessories regularly for damage and signs of wear.
- Check all metal components for possible breaks or cracks. Do not use the trailer if any metal components are cracked or damaged.
- Check the trailer for bent, defective, missing or loose fasteners or catches. Tighten loose fasteners or catches and replace damaged or missing parts.
- Inspect the fabric regularly for tears, worn spots or other signs of damage.
- Clean the child carrier regularly with warm water and a mild soap solution. Never use aggressive cleaning agents or solvents.
- Clean the wheel axles and lubricate all exposed moving parts with grease or oil. Always check the wheels and carry out maintenance at least once a year.
- **Storage:**
- Store your trailer and accessories in a dry place out of direct sunlight.
- Before storage, the child carrier must be dry to prevent the formation of mould or bacteria.

PARTS LIST



1 X Main frame



2 X Wheels



2 X Front wheels



1 X Blue Clamp



1 X Flag



1 X Tow bar



2 X Wheel Axle



2 X Screws
1 X Plastic holder

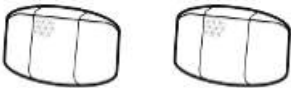

2 X Front Reflectors
(White)

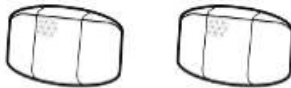

2 X Rear Reflectors
(Red)



2 X wheel Reflectors
(Yellow)

HOW TO ASSEMBLE AND USE

Unfold the Frame:

1. Raise both side panels to an upright position
2. Wearing the top of back seat cloth into the cross bar and locking the pin into the latch.
3. Ensure the cross bar is locked into place by pulling up and down on it.

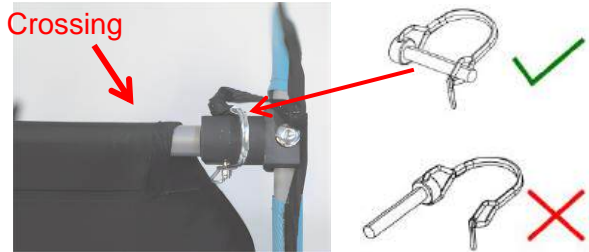
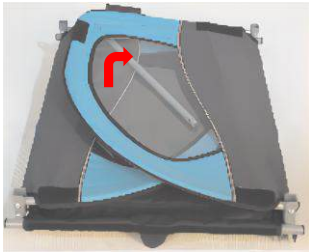

Attach The Storage Area:

1. Insert the velcro into the buckle on side panels.
2. Attach the velcro tightly.

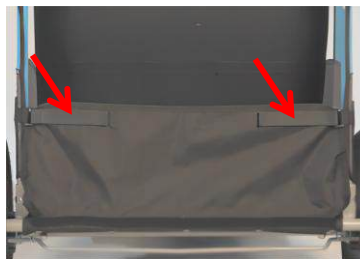

Attach The Canopy:

1. Starting at the bottom corner of the trailer, connect the velcro on each side and back walls of the trailer.
2. Roll the weather shield up into the velcro at the top of the canopy if you are not using it .



ATTACH THE REAR WHEELS

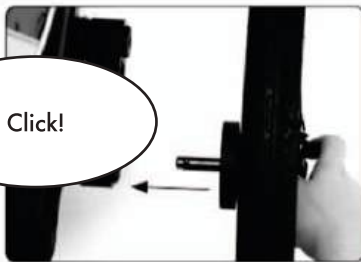

Click!



NOTICE!
The wheel guard protects the wheels from collisions with obstacles.

Insert the rear wheels into the openings on the frame. When you hear a click, the rear wheels are correctly fixed and locked in place.

Note: The rear wheels can be removed by pressing the button located in the middle of the wheel.

Warning: After assembly, check the locking by pulling both wheels back and forth! The wheels must not be able to be pulled out without pressing the button. Wheels that are not fully locked can come loose when riding, which can lead to accidents with life-threatening injuries.

Note: The bicycle trailer has a wheel guard. Always fold the wheel guard outwards when using it as a bicycle trailer. The wheel guard protects the rear wheels from collision.

ATTENTION!

THE CORRECT TIRES ARE ESSENTIAL! USE ONLY THE SUPPLIED TIRES AND KEEP THEM PROPERLY MAINTAINED. INFLATE TIRES TO 30-35 P.S.I. AND CHECK PRESSURE BEFORE EACH USE. DO NOT USE HIGHER PRESSURE TIRES AS THIS WILL MAKE THE TRAILER JUMPY AND PRONE TO TIPPING OVER WHEN LIGHTLY LOADED. WE RECOMMEND ONLY TIRES WITH ROAD TREAD. DO NOT USE OFF-ROAD TIRES.

ATTACH THE FRONT WHEEL



If the bicycle trailer has the drawbar or the jogger wheel set mounted, first remove these elements and insert the blue fastening hooks back into the holes provided. Make sure that the fastening hooks are closed.

Tip: To familiarise yourself with the assembly, we recommend that you first lift the bicycle trailer at the front, tilt it backwards and support it on the handlebar. Make sure that the surface under the trailer is clean and smooth so as not to soil or damage the textile cover. Later, when you are familiar with the assembly, it is enough to lift the trailer slightly at the front for this work.

1. lift the trailer at the front or tilt it backwards.
2. insert the buggy wheel into the buggy wheel holder as far as it will go until you hear and feel it engage.
3. to remove the buggy wheel, press the blue button and pull the buggy wheel out.

Caution: Make sure that the buggy wheel is correctly engaged and cannot come loose by itself ! If the buggy wheel is not correctly engaged, the buggy wheel can come loose, which can lead to accidents and injuries.

Caution: Never ride with a mounted buggy wheel when using the trailer as a bicycle trailer! The buggy wheel could hit obstacles, which could lead to accidents and injuries.

EXTEND & SECURE THE TOW BAR

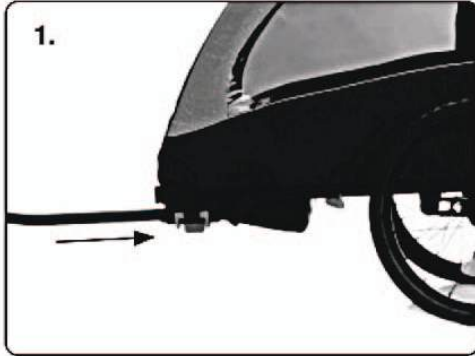

1. Insert the drawbar into the opening on the left side of frame. The opening is located under the front reflector.

2. Secure the drawbar with the blue clamp. To do this, insert steel bolt of the clamp into the hole on the side of the bicycle trailer and close the clamp. The clamp is securely closed as soon as you hear a loud clack.

Note: Opening and closing the clamp is not smooth and requires a certain amount of force. This is necessary to guarantee a secure hold of the clamp.

ATTENTION !

1. Steel bolt must always be locked with the clamp when the trailer is used.

2. Always make sure that the drawbar is securely mounted. Failure to do so may result in serious accidents and injuries.

INSERT THE SAFETY FLAG



1. Assemble the flag pole sections by sliding the top half of the pole into the opening of the bottom half of the pole.
2. Insert the flag pole into the sleeve located at the rear corner of the trailer.

WARNING: The safety flag is an important safety feature that warns others a trailer is present and on the bicycle. Always have the safety flag on the trailer when in use !

ASSEMBLING MOUNTING HOLDER OF DRAWBAR



1. Clipping the plastic holder onto the tube, make sure the screw holes are in the same position.
2. Using screws to fix the plastic holder.
3. Insert the drawbar and hook the elastic on the side of fabric.

ASSEMBLING THE REFLECTORS

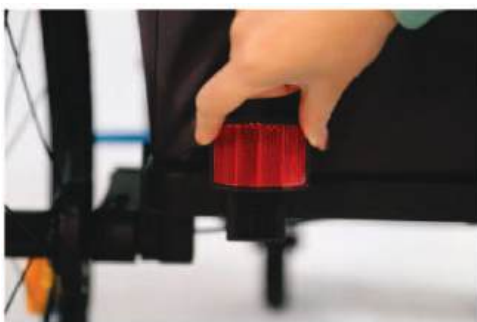

1. Insert two white reflectors into the holder on the front.
2. Insert two red reflectors into the holder on the back.
3. Insert two yellow reflector into the wheel.

USING THE PARKING BRAKE

The parking brake prevents the bicycle trailer from unintentionally rolling away when stationary. It is not suitable for braking a rolling bicycle trailer. Always apply the parking brake when you:

- 1.) Park buggy.
- 2.) Allow your child to get in and out of the trailer when using it as buggy or bicycle trailer.
- 3.) Lock the trailer so that it does not roll away.



The parking brake can be released by lifting the foot on the foot brake.



The parking brake can be fixed by placing the foot on the foot brake.

WARNING!

Always apply the parking brake after parking the trailer and when getting in and out of the trailer with the children. Check that the trailer cannot roll away by pulling it slightly forwards and backwards. An unsecured trailer could cause accidents with life-threatening injuries by rolling away or could roll away when getting in or out of the trailer, causing serious injuries to the children.

- Always engage parking brake at each stopover.
- If the rod can't be slid into socket easily, try to move the trailer forward slowly until brake is working.
- Never drive with the parking brake applied! This can damage the brake mechanism.

USING THE SAFETY HARNESS

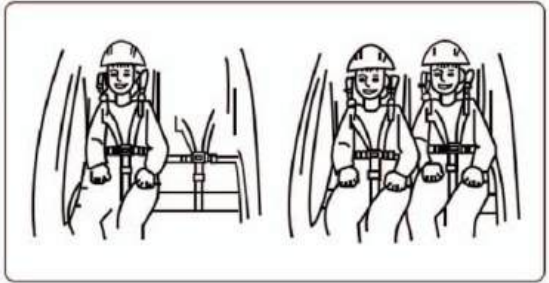
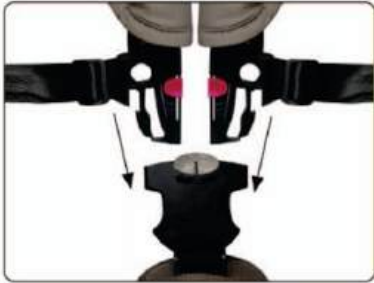

The 5-point safety harness system consists of two shoulder straps, two lap straps and a crotch strap secured in a buckle. Padded shoulder straps provide more comfort.

1. Open the straps by first pressing the red buttons and at the same time the black buttons on the buckle. The individual straps should now come out of the buckle.
 2. Let the crotch strap hang down towards the footwell and place the two shoulder straps and the lap straps to the sides of the seat for the time being, so that you can comfortably put your child into the seat.
 3. Place the child in the seat with the harness open.
 4. Guide the crotch strap with the buckle between the child's legs upwards to the upper body.
 5. Guide the hands away from the child.
 6. Pass the child's hands between the shoulder straps and lap straps. Place the shoulder straps over the child's shoulders. Now insert the ends of the straps into the buckle.
- Tip:** The seat belts can be adjusted to the child's height.
7. Adjust the seat belts so that the child is held securely by the belts, but not so tight that the seat belts cut in.

Tip: If a flat hand can be slid between the straps and the baby's body, the straps are usually adjusted correctly.

Warnings:

- The distance between the shoulder and lap belts and the child's body should be as small as possible so that the child is held optimally in the seat. If the distance is too great, the child cannot be restrained sufficiently in the seat, which can lead to life-threatening injuries in the event of an accident. If the distance is too small, the seat belts may possibly cut into the child's body.
- Always fasten the child's seat belt! Your child could otherwise suffer life-threatening injuries in dangerous situations.
- Seat belts that are adjusted too loosely or buckles that are not properly fastened can cause life-threatening injuries to your child in the event of an accident.
- Avoid serious injury from falling or sliding out. Always properly secure the passengers with the safety harness.

- It may be dangerous to leave your child unattended. Never leave your child unattended in or near the bicycle trailer.
- Never transport babies under 6 months or children who cannot yet sit independently.

ATTACHING TO BICYCLE

Check whether the towing bike is approved by the manufacturer for towing trailers! Pulling trailers with an unsuitable towing bike can lead to frame fractures and accidents with life-threatening injuries.

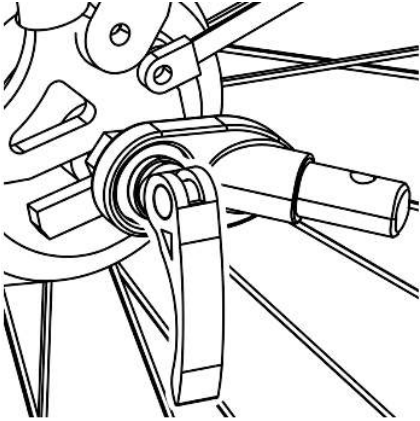

1. Quick-release Axle:

Remove the quick-release from the left side of bike's rear axle. Install the hitch between the quick-release and frame. Tighten the quick-release following the bike manufacturer's manual. Hitch can remain on the bike when the trailer is removed.

WARNING: The tension-adjusting nut must engage the threads for at least five full turns in order to ensure adequate clamping force for holding the rear wheel securely. Failure to tighten the tension-adjusting nut fully may result in accidents with serious injury or death. If the quick-release skewer is too short, it must be replaced. Consult a professional bicycle mechanic for the appropriate parts and assistance.

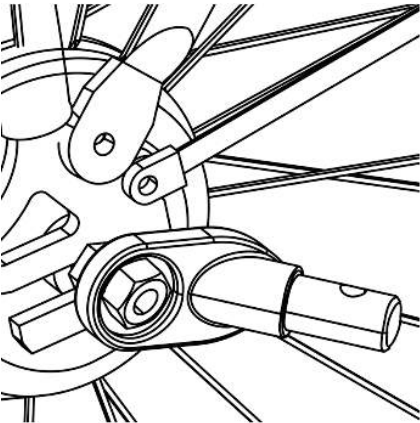

2. Nutted Axle:

Unscrew the nut with washer from the left side of bike's rear axle. Install the hitch onto the axle and screw the nut back on with the washer.

WARNING: The axle nut must engage the threads for at least five full turns in order to ensure adequate clamping force for holding the rear wheel securely. Failure to tighten the nut fully may result in accidents with serious injury or death. If the axle is too short, the Universal Hitch cannot be used! Consult a professional bicycle mechanic for the appropriate parts and assistance.

3. Thru Axle: The universal hitch doesn't fit a bike with thru axle. Please consult the retailer for possible solution.

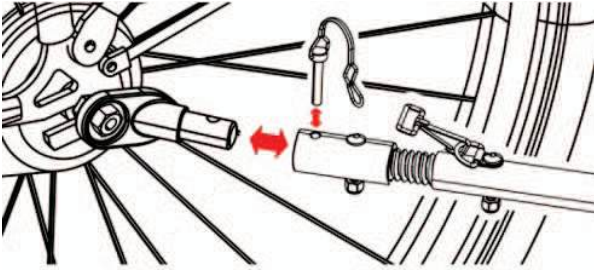

Connect the coupler on the tow bar and secure the safety pin.

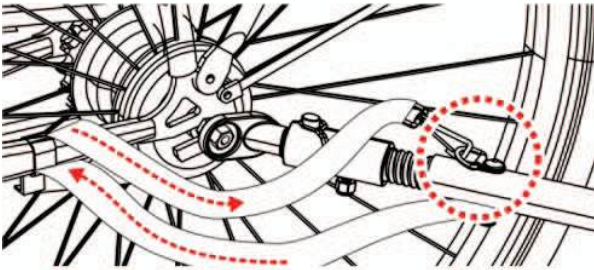

Once the tow bar is attached, wrap safety belt around the frame of the bike and hook onto the D-ring on the tow bar.

CHECK BEFORE USE

1. Wheels are properly secured to the trailer.
2. Tires are inflated to recommended pressure on the tire side wall.
3. Tow bar is properly secured to the trailer.
4. Hitch is properly secured to the bicycle.
5. All safety pins are securely locked in place.
6. Safety strap on the tow bar is properly installed.
7. Make sure that bicycle is in proper working order, especially brakes and tires (refer to bicycle manufacturer's instructions).
8. Safety flag is in place.